

#	DESCRIPTION	SP #	NOTES
1	Hardware Kit	SP-0136	
2	Caster (x2)	SP-0137	
3	Caster (x2)	SP-0138	
4	Battery (x2)	SP-0139	12V 12Ah
5a	Type B Power Supply Cable	SP-0140	
5b	Type C Power Supply Cable	SP-0151	
5c	Type G Power Supply Cable	SP-0152	
6	Support Roller (x2)	SP-0156	
7	Belt	SP-0207	Motor to shaft
8	PCB KIT	SP-0224	1 PCB version
9	PCB KIT (x3)	SP-0225	3 PCB version
10	Switch ON/OFF	SP-0226	
11	Control panel with sticker	SP-0227	
12	Emergency stop switch	SP-0228	
13	Fan V1	SP-0229	3 PCB version
14	Fan V2	SP-0232	1 PCB version
15	Lower limit switch	SP-0231	

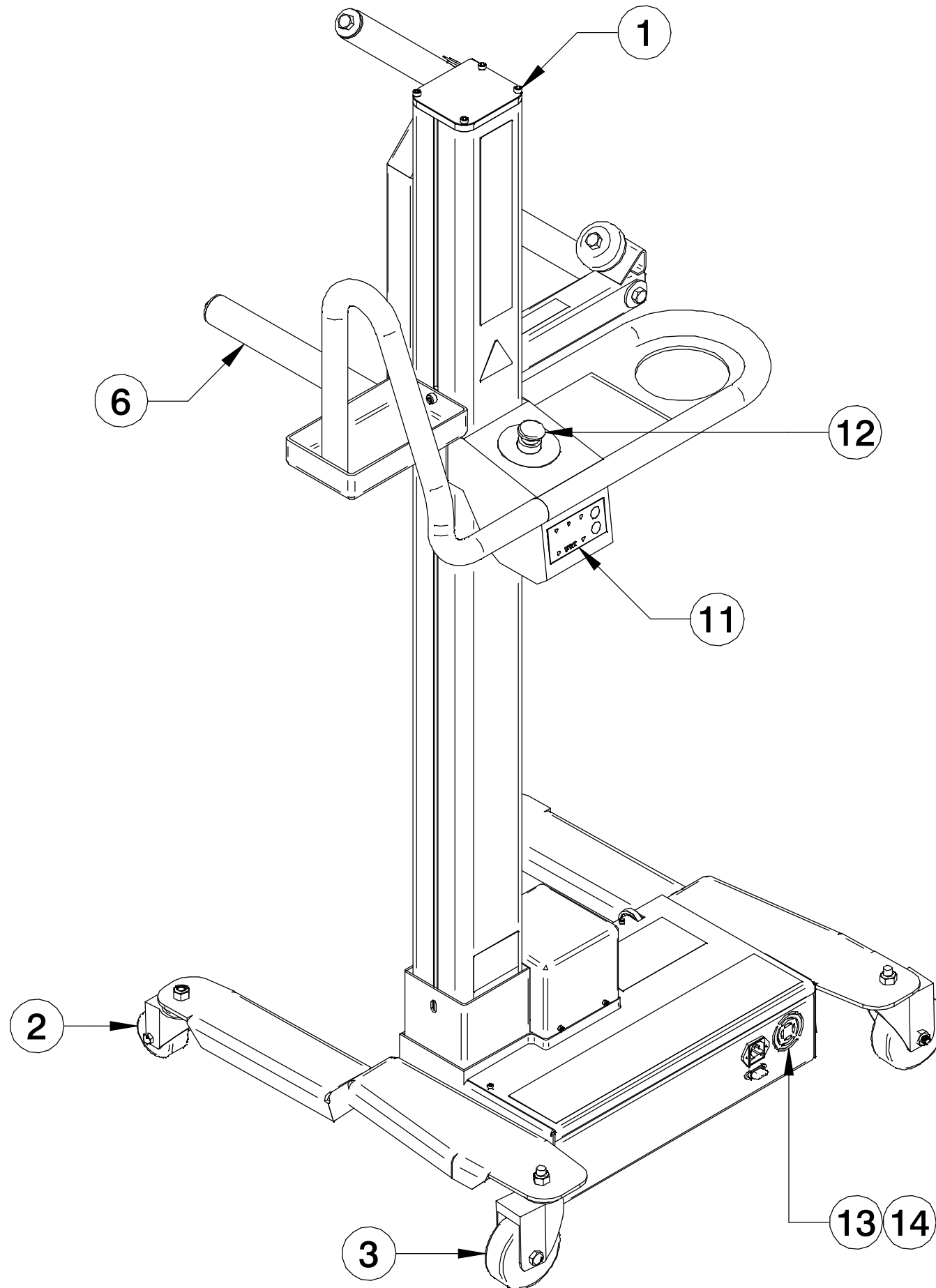

	Wall Plug
5a	
5b	
5c	

